

Coordination Compound

Part-01

INTRODUCTION AND TERMINOLOGY AND CLASSIFICATION OF LIGANDS

INTRODUCTION

- The concept of coordination compounds arises from the complex formation tendency of transition elements.
- These compounds play a vital role in our lives. Haemoglobin of blood and chlorophyll of plants are also coordination compounds of Fe, Mg respectively.

TYPE OF COMPOUNDS

MOLECULAR OR ADDITION COMPOUNDS

- When two or more simple salts are chemically combined together in fixed proportion by weight the molecular or addition compounds are formed.
- Some common examples are as follows.

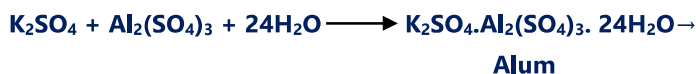

- Depending upon the behaviour in an aqueous solution they are of two types
 - Double salt
 - Coordination or complex compounds.

(I) DOUBLE SALT

The addition compounds which lose their identity in aq. solution and get completely ionised in water.

- Ex.** (i) $\text{K}_2\text{SO}_4 \cdot \text{Al}_2(\text{SO}_4)_3 \cdot 24\text{H}_2\text{O}$ (Potash Alum)
 (ii) $\text{FeSO}_4(\text{NH}_4)_2\text{SO}_4 \cdot 6\text{H}_2\text{O}$ (Mohr's salt)
 (iii) $\text{KCl} \cdot \text{MgCl}_2 \cdot 6\text{H}_2\text{O}$ (Carnallite)

(II) COORDINATION OR COMPLEX COMPOUNDS

- Those molecular or addition compounds which retain their identity in aq. solution or lose the identity of constituents are called complex salt.
- Complexes retain their identity in aqueous solution. i.e., they do not dissociate into separate ion.

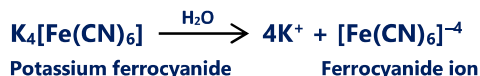

- On the basis of type of ligands complex compounds are divided as follows :

(i) Homoleptic complexes :

Complex in which all the ligands are identical is called homoleptic complex.



(ii) Heteroleptic complexes :

Complex in which all the ligands are not identical is known as heteroleptic complex.

Ex. $[\text{Fe}(\text{en})_2\text{Cl}_2]^+$

TERMINOLOGY OF COMPLEX COMPOUNDS**(A) COMPLEX ION/COORDINATION SPHERE**

- An aggregate of metal ion with anions, cation or neutral molecules is called as **complex ion**.
- It is a non-ionisable part of complex compound.

(B) CENTRAL METAL ION

- The metal ion which forms complex ion in combination with anions, cation or neutral molecules is called as **central metal ion**.
- Central metal ion acts as an electron pair acceptor and forms coordinate bonds with donor species.
- Generally belongs to d block because d block elements have tendency to form complex due to their high charge density and availability of vacant orbitals.

(C) COORDINATION NUMBER

The total number of coordinate bonds formed by central metal ion with donor species is called as coordination number of central metal ion.

(D) IONISATION SPHERE

The part of complex compound which get ionised is known as ionisation sphere.

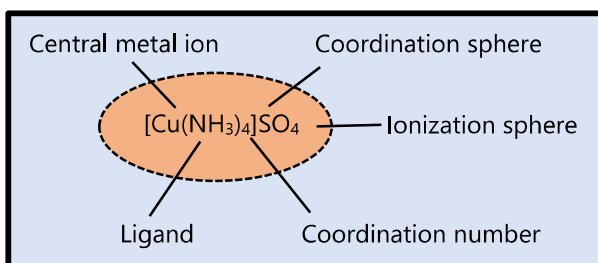
**(E) OXIDATION STATE**

It is a number which represents the electrical charge on the central metal atom of a complex ion.

Ex. the oxidation number of Fe, Co and Ni in $[\text{Fe}(\text{CN})_6]^{4-}$, $[\text{Co}(\text{NH}_3)_6]^{3+}$ and $\text{Ni}(\text{CO})_4$ is +2, +3 and zero respectively.

(F) CHARGE ON THE COMPLEX ION

It is the algebraic sum of the total charge of the donor species and central metal ion.

(G) LIGANDS

- (i) The anions, cation or neutral molecules which combine with central metal ion to form complex ion are called as ligands.
- (ii) They act as electron pair donor (Lewis bases) which donate e^- pair to central metal ion and form coordinate bonds.
- (iii) no. of e^- pair donated by a ligand to central metal ion is equal to its denticity.

(H) NAMING OF LIGANDS

- (i) o-suffix is used in the name of anionic ligands.
- (ii) ium-suffix is used in the name of cationic ligands.

Coordination Compound

Part-02

Classification of ligands :- On the basis of denticity.

1. Monodentate ligands : Which donate one e^- pair to the central metal ion.

Neutral monodentate ligands

NH_3	ammine
H_2O	aqua
NO	nitrosyl
PH_3	phosphine
PPh_3	triphenyl phosphine
O_2	dioxygen
N_2	dinitrogen
$\text{CH}_3\text{-OH}$	methyl alcohol
$\text{CH}_3\text{-NH}_2$	methyl amine
NH_2CONH_2	urea
NH_2NH_2	hydrazine
$\text{CH}_3\text{-O-CH}_3$	dimethyl ether
CO	carbonyl
CS	thiocarbonyl

Cationic monodentate ligands :

O_2^+	oxygenium
NO^+	nitrosylium or nitrosonium
NO_2^+	nitronium
	hydrazinium

Anionic monodentate ligands :

F^-	Fluorido / fluoro
Cl^-	Chlorido / chloro
Br^-	bromido / bromo
I^-	iodido / iodo
O^{2-}	oxido/oxo
S^{2-}	sulphido/sulpho
OH^-	hydroxido / hydroxo
O_2^-	superoxido / superoxo
O_2^{2-}	peroxido / peroxy
N^{3-}	nitrido
N_3^-	azido
$(NH_2)^-$	amido
NH^{2-}	imido
H^-	hydrido

2. Bidentate ligands : Ligands which donate two e^- pair to the central metal ion.

Ligands having denticity 2 or more than 2 form a stable ring with central metal ion that's why they are known as chelating ligands.

no. of rings = Denticity - 1

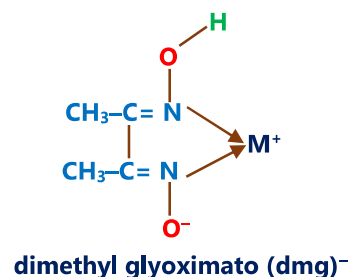
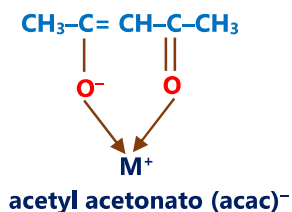
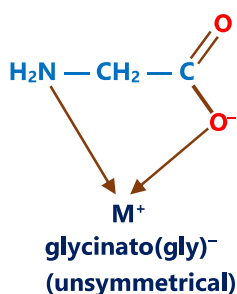
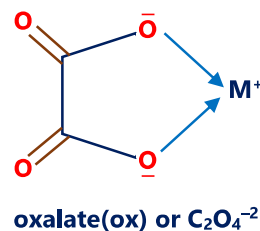
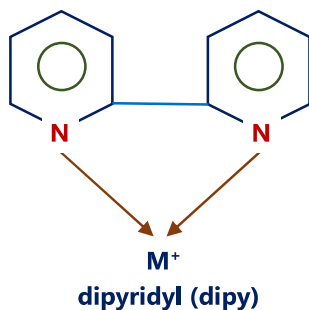
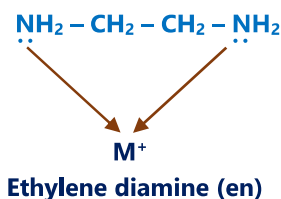

Coordination Compound Part-02

3. Polydentate ligands

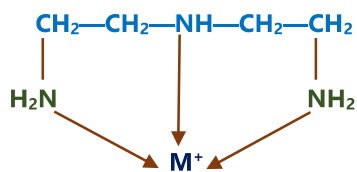

Diethylenetriamine(dien)
Tridentate

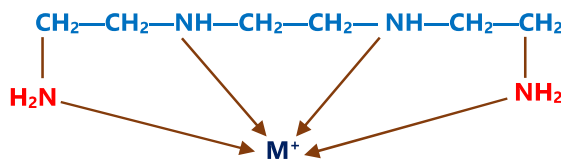

Triethylenetetraamine (trien)
Tetradentate

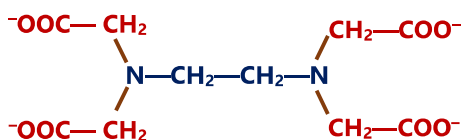

Ethylenediaminetetraacetate (EDTA⁴⁻)
Hexadentate

4. Ambidentate ligand : Ligands which have two different donor atoms but at one time one donor atom can donate electron pair are called ambidentate ligands.

Ambidentate ligands have same molecular formula but have different donor atom.

- (i) $M \leftarrow \bar{C} \equiv N$ cyanido (CN)
 $M \leftarrow N \equiv \bar{C}$ isocyanido (NC)
- (ii) $M \leftarrow \bar{O} - C \equiv N$ cyanato / cyanato-O
 $M \leftarrow N \equiv C - \bar{O}$ isocyanato / cyanato-N
- (iii) $M \leftarrow \bar{S} - C \equiv N$ Thiocyanato / Thiocyanato-S
 $M \leftarrow N \equiv C - \bar{S}$ Isothiocyanato/thiocyanato-N
- (iv) $M \leftarrow \bar{O} - N = O$ Nitrito / Nitrito-O

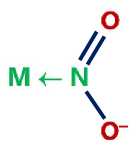

Nitro / Nitrito-N

5. Flexidentate ligands : Ligands which can change their denticity.

SO_4^{2-} , $S_2O_3^{2-}$, CO_3^{2-} , NO_3^- , CH_3COO^- etc are generally act as monodentate ligand but in some compound they can act as bidentate ligand

- eg. (i) $[Co(NH_3)_5(SO_4)]Cl$ in this complex SO_4^{2-} act as a monodentate ligand.
 (ii) $[Co(en)_2(SO_4)]Cl$ in this complex SO_4^{2-} act as a bidentate ligand.

Coordination Compound

Part-03

CLASSIFICATION OF LIGANDS – SYNERGIC BONDING

On the basis of nature of bonding between central metal atom and ligand:-

(i) Normal or classical ligands:

Ligand which only donate electron pair to central metal ion & form coordinate (σ) bond

e.g. OH^- , NH_2^- , Cl^- , N^{3-} , O^{2-} etc.

(ii) Non classical or π -acid or π -acceptor ligands :-

Ligand which donate electron pair to central metal ion & form coordinate σ bond but simultaneously they accept electron pair from central metal ion through back bonding or synergic bonding.

e.g. CO , NO^+ , CN^- , R_3P , R_3As etc.

Synergic bonding in metal carbonyls :-

They are of 2 types

(a) σ donor and π acceptor ligands

Ligands which donate their lone pair to central metal ion through σ bond and simultaneously accept e^- pair from central metal ion through π bond.

The electronic configuration of CO molecule shows that it has lone pair of electrons on carbon and oxygen atom each. Carbon atom can donate its electron pair of a transition metal atom (M), forming $\text{OC} \rightarrow \text{M}$ coordinate bond.

Since the metal atom in metal carbonyl is in zero oxidation state, the formation of $\text{M} \leftarrow \text{CO}$ σ bond accumulates a negative charge on the metal atom. The accumulation of negative charge on the metal atom can be counter balanced by transferring some negative charge from the metal atom to CO molecule (ligand). This transfer can be done by making a $\text{M} \rightarrow \text{CO}$ π bond by the overlap between an appropriate filled d orbital on the metal atom and empty π_y^* or π_z^* molecular orbital of CO molecule. This type of bonding between M and CO is called **synergic bonding**.

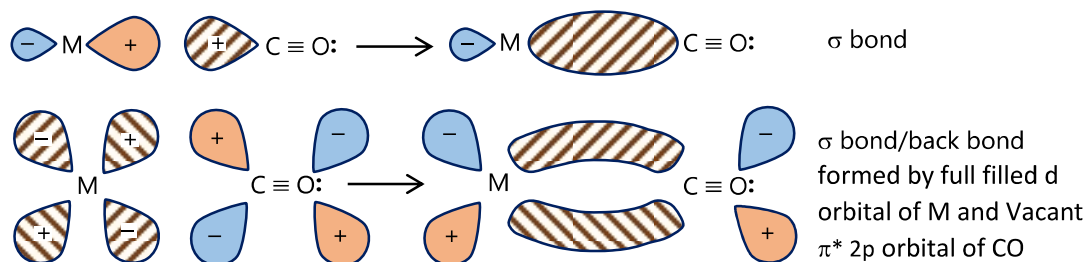

[Schematic of orbital overlaps in metal carbonyls]

Conclusion of synergic bonding :

- (a) M–C bond strength increases; M–C bond length decreases; because double bond character increases
- (b) C–O bond strength decreases; C–O bond length increases; because bond order of C–O decreases (CO accepts e^- pair into its antibonding molecular orbital)

(b) π -donor and π -acceptor ligands

Ligands which donate π electron pair to central metal ion & also accept electron pair from central metal ion through synergic bonding.

- (i) $H_2C=CH_2$ (η^2 - ethylene) : it is a 2π electron donor

- (ii)  (η^6 - benzene) : it is a 6π electron donor

- (iii)  / $[C_5H_5]^-$ (η^5 -cyclopentadienyl) : it is a 6π electron donor

for example



sandwich compound

- (a) $[Cr(\eta^6-C_6H_6)_2]$
- (b) $[Fe(\eta^5-C_5H_5)_2]$ ferrocene (sandwich compound)
- (c) $K[PtCl_3(\eta^2-C_2H_4)]$ (Zeise's salt)

Coordination Compound

Part-04

Calculation of Oxidation Number, Coordination Number And No. of Chelate Ring

Number of chelate ring (C.R.) = denticity – 1

Coordination no. (C.N.) = total no. coordinate bonds formed by ligands with CMA

Oxidation no. (O.N.) = total charge on CMA

Example

(1) $K_4[Fe(CN)_6]$

$$+4 + x - 6 = 0$$

$$x = +2$$

(a) O.N. of Fe is +2

(b) CN^- is a monodentate ligand.

$$C.N. \text{ of Fe} = 1 \times 6 = 6$$

(c) No. of chelate ring = $1 - 1 = 0$

(2) $[Cu(NH_3)_4]SO_4$

$$x + 0 - 2 = +2$$

$$x = +2$$

(a) O.N. of Cu is +2

(b) NH_3 is a monodentate ligand

$$C.N. \text{ of Cu} = 1 \times 4 = 4$$

(c) No. of chelate ring = $1 - 1 = 0$

(3) $[Co(en)_3]Cl_3$

$$x + 0 - 3 = +3$$

$$x = +3$$

(a) O.N. of Co is +3

(b) en is a bidentate ligand

$$C.N. \text{ of Co} = 2 \times 3 = 6$$

(c) No. of chelate ring = $2 - 1 = 1 \times 3 = 3$

(4) [Cu(dien)₂]SO₄

$$x + 0 - 2 = +2$$

$$x = +2$$

(a) O.N. of Cu is +2

(b) dien is a tridentate ligand

$$\text{C.N. of Cu} = 3 \times 2 = 6$$

$$\text{(c) No. of chelate ring} = 3 - 1 = 2 \times 2 = 4$$

(5) [Ca(EDTA)]²⁻

$$x - 4 = -2$$

$$x = +2$$

(a) O.N. of Ca is +2

(b) EDTA⁴⁻ is a hexadentate ligand.

$$\text{C.N. of Ca} = 1 \times 6 = 6$$

$$\text{(c) No. of chelate ring} = 6 - 1 = 5$$

(6) K₃[Co(ox)₃]

$$+3 + x - 6 = 0$$

$$x = +3$$

(a) O.N. of Co is +3

(b) ox is a bidentate ligand

$$\text{C.N. of Co} = 2 \times 3 = 6$$

$$\text{(c) No. of chelate ring} = 2 - 1 = 1 \times 3 = 3$$

Coordination Compound

Part-05

IUPAC NOMENCLATURE

IUPAC NOMENCLATURE OF COORDINATION COMPOUNDS

The present system of nomenclature derived from the suggestions of **Alfred Werner** and recommended by the Inorganic Nomenclature Committee of the I.U.P.A.C. The main rules of naming of complexes are -

- Like simple salts, the positive part of the coordination compound is named first.
Ex. $K_4[Fe(CN)_6]$ the naming of this complex starts with Potassium.
- In the naming of complex ion, ligands are to be named before the naming of central metal ion.
- If no. of ligands are more than one then their presence is indicated by prefixes like di, tri, tetra etc. but in case of polydentate ligands different prefixes such as bis, tris are used.
- When more than one type of ligand is present in the complex, then the ligands are named in the alphabetical order.
- If the complex is neutral or cationic then the central metal ion is to be named as it is.
If the complex is anionic complex then the name of central metal ion ends in 'ate'
- After the naming of central metal ion, oxidation state of central metal ion is written in Roman numeral.

The naming of some of the complexes is done as follows – (as per IUPAC)

Complex Compounds	IUPAC Name
(i) $K_4[Fe(CN)_6]$	Potassium hexacyanidoferrate (II)
(ii) $K_2[HgI_4]$	Potassium tetraiodidomercurate (II)
(iii) $[Co(NH_3)_6]Cl_3$	Hexamminecobalt (III) chloride
(iv) $[Cr(H_2O)_4Cl_2]Cl$	Tetraaquadichlorochromium (III) chloride
(v) $[Pt(NH_3)_2Cl_4]$	Diammine tetrachloroplatinum (IV)
(vi) $[Co(NH_3)_3Cl_3]$	Triamminetrichlorocobalt (III)
(vii) $K_3[Co(NO_2)_6]$	Potassium hexanitrocobaltate (III)
(viii) $Na_2[Fe(CN)_5NO]$	Sodium pentacyanonitrosoniumferrate (II)
(ix) $[NiCl_4]^{-2}$	Tetrachloronickelate(II) ion
(x) $[Ru(NH_3)_5Cl]^{+2}$	Pentamminechlororuthenium (III) ion
(xi) $[Fe(en)_3]Cl_3$	Tris (ethylenediamine) iron (III) chloride

- (g) If coordination compound contains 2 coordination spheres then both spheres should have opposite charges. Name of cationic part is written first following the name of anionic sphere according to the general IUPAC rule.

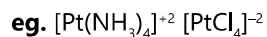

Tetraammineplatinum (IV) tetrachloroplatinate (II)

- (h) If in a complex compound bridging ligands is present then μ – prefix is used before its name.

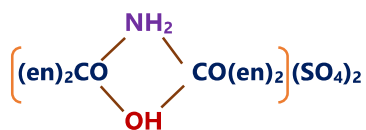

bis (ethylene diamine) cobalt (III) – μ -amido- μ -hydroxo bis (ethylenediamine) cobalt (III) sulphate

Coordination Compound

Part-06

EAN

Effective atomic number (EAN) – Total no. of e⁻ associated with central metal ion in a complex is equal to effective atomic number.

$$\text{EAN} = \text{Atomic number} - (\text{Oxidation state}) + (2 \times \text{Coordination number})$$

Examples :

Complex	Metal (Oxidation State)	Atomic Number of Metal	Coordination number	Effective atomic number (E.A.N)
[Cu(NH ₃) ₄]SO ₄	+2	29	4	(29-2) + (4×2) = 35
[Co(NH ₃) ₆]Cl ₃	+3	27	6	(27-3) + (6×2) = 36
K ₂ [Hg(I) ₄]	+2	80	4	(80-2) + (4×2) = 86
[Ag(NH ₃) ₂]Cl	+1	47	2	(47-1) + (2×2) = 50

Werner's Theory Of Coordination Compounds

Introduction

Werner's Coordination Theory was proposed in 1898 by Swiss chemist Alfred Werner. Through extensive studies on coordination compounds' physical, chemical, and isomeric properties, Werner formulated key postulates that explain their bonding and structure.

Postulates of Werner's Theory

Werner proposed the following fundamental concepts regarding **coordination compounds**:

1. In a coordination compound, the central metal atom exhibits **two types of valencies**:
 - **Primary valency** (ionizable)
 - **Secondary valency** (non-ionizable)
2. Primary valencies correspond to the oxidation state of the metal and are satisfied by negative ions (e.g., Cl^- , SO_4^{2-}).
3. Secondary valencies correspond to the coordination number of the metal and are satisfied by either neutral molecules (e.g., NH_3 , H_2O) or negative ions (e.g., CN^- , Cl^-).
4. The number of secondary valencies (coordination number) is fixed for each metal, and the spatial arrangement of ligands around the metal is determined.
5. The ligands attached via secondary valencies form a definite geometric shape known as a polyhedron.
 - Common geometries in coordination compounds include tetrahedral, octahedral, and square planar arrangements.
 - The ligands arranged around the central metal ion occupy fixed positions in space, giving the complex a definite geometry.
 - For example, in $\text{CoCl}_3 \cdot 5\text{NH}_3$, one Cl^- shifts from primary valency to secondary valency.
 - As a result, only two Cl^- ions remain ionizable, while 5 NH_3 molecules and 1 Cl^- ligand form coordinate bonds with Co^{3+} .

Types of Valencies

Metals exhibit two types of valencies: Primary valency and Secondary valency.

Primary Valencies (Oxidation State)

- Primary valencies are ionizable and correspond to the oxidation state of the metal.
- They are observed in simple salts such as CoCl_3 , CuSO_4 , and AgCl .
- For example, in CoCl_3 , CuSO_4 , and AgCl , the primary valencies of Co, Cu, and Ag are +3, +2, and +1, respectively.

Secondary Valencies (Coordination Number)

- Secondary valencies are non-ionizable and determine the coordination number of the metal.
- These are satisfied by ligands (neutral molecules or ions) that form coordinate bonds with the metal.
- Examples of coordination complexes:
- - $[\text{Co}(\text{NH}_3)_6]^{3+} \rightarrow$ Coordination number = 6
 - $[\text{Cu}(\text{NH}_3)_4]^{2+} \rightarrow$ Coordination number = 4
 - $[\text{Ag}(\text{NH}_3)_2]^+ \rightarrow$ Coordination number = 2

Werner's Representation Of Complexes

Key Notations:

- Dotted lines (.....) \rightarrow Represent Primary Valency (Ionizable).determines ionizability.
- Continuous lines (—) \rightarrow Represent Secondary Valency (Non-ionizable).determines the geometry and coordination number.
- As the number of ionizable Cl^- ions decreases, the ionization and electrical conductivity of the compound decrease.

1. $\text{CoCl}_3 \cdot 6\text{NH}_3$

- Primary valency: 3 (satisfied by 3 Cl^- counter ions, ionizable).
- Secondary valency: 6 (satisfied by 6 NH_3 molecules, non-ionizable).
- Structure: Octahedral (since six NH_3 ligands surround the Co^{3+} ion)

ALLEN

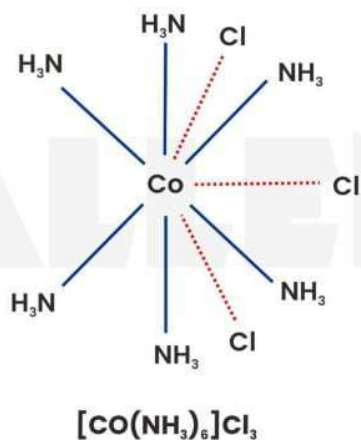

2. $\text{CoCl}_3 \cdot 5\text{NH}_3$

- Primary valency: 2 (satisfied by 2 Cl^- counter ions, ionizable).
- Secondary valency: 6 (satisfied by 5 NH_3 molecules and 1 Cl^- ligand, non-ionizable).
- Structure: Octahedral.
- Here, one Cl^- acts as a secondary valency (inside the brackets), while the other two Cl^- ions act as primary valencies (outside the brackets and ionizable).

ALLEN

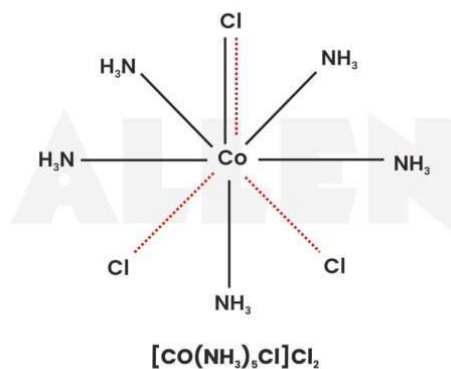

3. $\text{CoCl}_3 \cdot 4\text{NH}_3$

- Primary valency: 1 (satisfied by 1 Cl^- counter ion, ionizable).
- Secondary valency: 6 (satisfied by 4 NH_3 molecules and 2 Cl^- ligands, non-ionizable).
- Structure: Octahedral

ALLEN

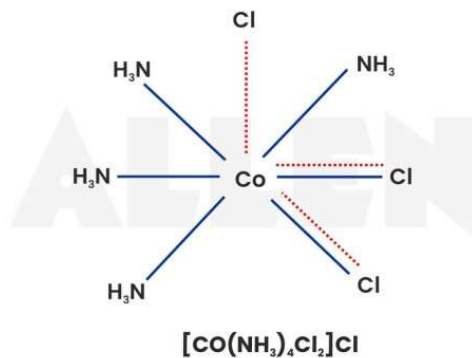

-
- One Cl^- is ionisable (primary valency, outside the brackets).
 - Two Cl^- ligands are inside the brackets (secondary valencies, non-ionizable).

Experimental Evidence Supporting Werner's Theory

Several experimental observations, including precipitation reactions and electrical conductance studies, support Werner's coordination theory.

(a) Precipitation of Primary Valencies Using a Suitable Reagent

- When a coordination compound is treated with AgNO_3 solution, the ionizable chloride ions (Cl^-) react with silver ions to form an AgCl precipitate.
- **Example:**
- - $[\text{Fe}(\text{NH}_3)_6]\text{Cl}_3$ produces 3 moles of AgCl upon reaction with AgNO_3 , confirming that the three Cl^- ions are ionizable and exist outside the coordination sphere.
 - The complex dissociates as:

(b) Electrical Conductance of Complexes

- The electrical conductivity of a coordination compound in an aqueous solution depends on the number of free ions present.
- The greater the number of ions, the higher the electrical conductivity.
- **Example:**
- - The electrical conductance of an aqueous solution of $[\text{Fe}(\text{NH}_3)_6]\text{Cl}_3$ is higher than that of $[\text{Fe}(\text{NH}_3)_5\text{Cl}]\text{Cl}_2$ since the former releases more ions in solution.
 - Dissociation of $[\text{Fe}(\text{NH}_3)_5\text{Cl}]\text{Cl}_2$ in water:
 - Only three ions are produced here, leading to lower conductivity than $[\text{Fe}(\text{NH}_3)_6]\text{Cl}_3$, which dissociates into four ions.

COORDINATION COMPOUNDS

VALENCE BOND (VB) THEORY:

Valence bond treatment of bonding in complexes was mainly developed by **Pauling**.

It explains satisfactorily the structure and magnetic properties of a large number of coordinate compounds. The salient features of the theory are summarized below.

(i) The central metal ion has a number of empty orbitals for accommodating electrons donated by the ligands. The number of empty orbitals is equal to the coordination number of the metal ion for the particular complex.

(ii) The metal orbitals and ligand orbitals overlap to form strong bonds. Now we know that greater the extent of overlapping, stronger will be the bond and hence, more stable will be the complex. In order to achieve greater stability, the atomic orbitals (s,p or d) of the metal ion hybridize to form a new set of equivalent hybridized orbitals with definite directional properties. These hybrid orbitals now overlap with the ligand orbitals to form strong chemical bonds.

Some of the common types of hybridization and geometry of the complexes formed by them are given below:

Table 1.4. Coordination Numbers, Hybridisation and Molecular Geometry of Various Complexes

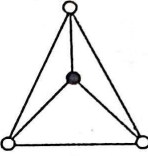
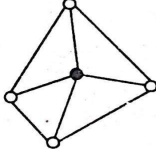
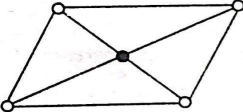
C. No.	Hybridisation	Molecular geometry
2	sp	 Linear
3	sp^2	 Trigonal planar
4	sp^3	 Tetrahedral
4	dsp^2 or sp^2d	 Square planar

physic

4 dsp^3 or sp^3d

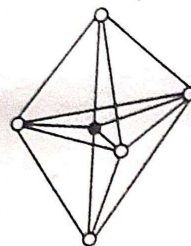

Trigonal bipyramid

6 d^2sp^3 or sp^3d^2

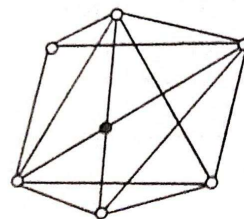

Octahedral

(iii) The d-orbitals involved in the hybridization may be either inner (n-1) d-orbitals or outer nd-orbitals. The complexes formed in these two ways are referred to as low spin and high spin complexes, respectively.

(iv) The non-bonding metal electrons occupy the inner d-orbitals which do not participate in hybridization and thus, in bond formation with the ligand.

(v) Each ligand contains a lone pair of electrons.

(vi) A covalent bond is formed by the overlap of a vacant hybridized metal orbital and a filled orbital of the ligand. The bond is also sometimes called as a coordinate bond

(vii) If the complex contains unpaired electrons, it is paramagnetic in nature, while if it does not contain any unpaired electrons, it is diamagnetic in nature.

The magnetic moment of the complex calculated by using the formula

$$(\mu) = \sqrt{n(n+2)} \text{ BM}$$

(ix) Under the influence of a strong ligand, the electrons can be forced to pair up against the Hund's rule of maximum multiplicity.

Let us consider a few examples to illustrate the valence bond theory.

1. OCTAHEDRAL COMPLEXES:

The octahedral complexes result from d^2sp^3 (inner orbital complexes) or sp^3d^2 (outer orbital complexes) hybridisation.

i. Inner orbital complexes:

In these complexes the d-orbitals involved in the hybridisation belong to lower quantum number, ie, (n-1).

ex :- **Formation of ferrocyanide ion, $[\text{Fe}(\text{CN})_6]^{4-}$**

- ❖ In this complex the central atom is "Fe".
- ❖ The electronic configuration of the central atom Fe and the ion Fe^{2+} present in ferrocyanide ion is depicted below:

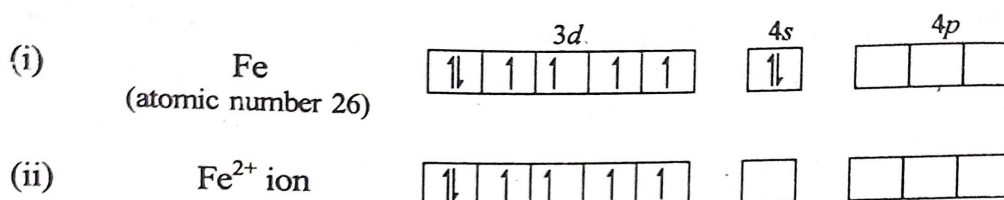

- ❖ Note that the Fe ion does not contain any empty 3d orbital hence, it should not form a complex ion but it is not so. In the presence of cyanide ligand, the electrons in the 3d orbitals are forced to pair up against the Hund's rule of maximum multiplicity [postulate (ix)] in order to accommodate the electrons donated by the ligands. Thus, after pairing up against Hund's rule, the electronic configuration of the Fe becomes as follows:

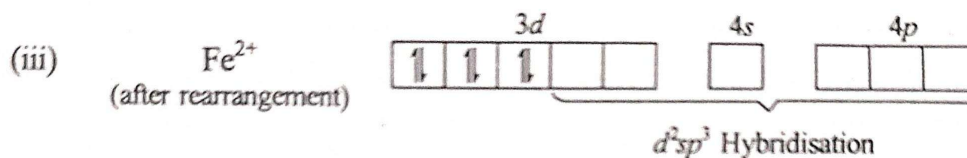

In this state Fe^{2+} undergoes d^2sp^3 hybridisation to form six d^2sp^3 hybrid orbitals, each of which accepts electron pair donated by CN^- ions (each cyanide ion donates a pair of electrons).

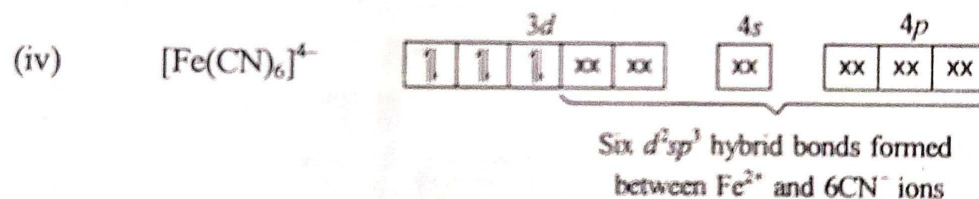

(6 CN^- ions donate 12 electrons marked by $\times\times$)

The resulting complex is "inner octahedral" and it should be diamagnetic as it has no unpaired electrons.

ii. Outer orbital complexes:

In these complexes s, p as well as d-orbitals involved in hybridisation belong to the highest quantum number (n)

- ❖ Complexes formed by the use of inner orbitals are diamagnetic or have reduced paramagnetism. They are called low-spin complexes.
- ❖ On the other hand, complexes formed by the use of outer n d orbitals will be paramagnetic. These complexes are called high-spin or spin-free complexes.
- ❖ The outer orbital complexes have a greater number of unpaired electrons.
- ❖ Let us take an example to illustrate the formation of outer orbital complexes.

ex:-**Formation of $[\text{CoF}_6]^{3-}$:**

In this complex the central atom is cobalt

The electronic configuration of cobalt (at. number 27) and Co^{3+} ion present in the given complex are as follows:

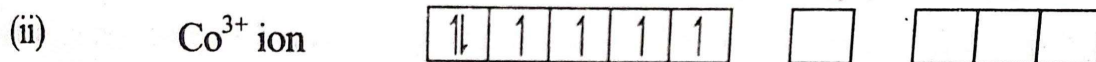
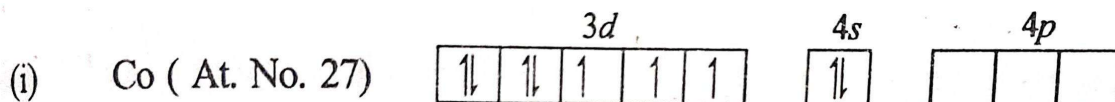

- ❖ Physical experiments show that $[\text{CoF}_6]^{3-}$ ion has paramagnetic character corresponding to the presence of four unpaired electrons in 3d orbital. Thus, to get six hybrid orbitals, none of the 3d orbital is involved in hybridisation. This is also in accordance with the fact that the fluoride ion is a weak ligand and cannot force the pairing up of electrons against Hund's rule.
- ❖ To account for the paramagnetic character of the ion, Huggin assumed that 4d (instead of 3d) orbitals are involved in hybridisation. In other words, one 4s, three 4p and two 4d orbitals mix to give six equivalent (sp^3d^2) hybrid orbitals which can accept six lone pairs donated by six ligands (i.e., F^- ion) to form $[\text{CoF}_6]^{3-}$ ion.

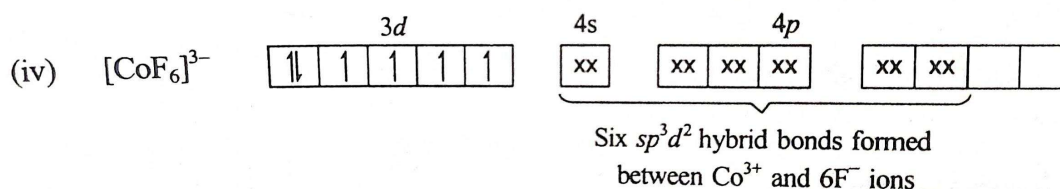
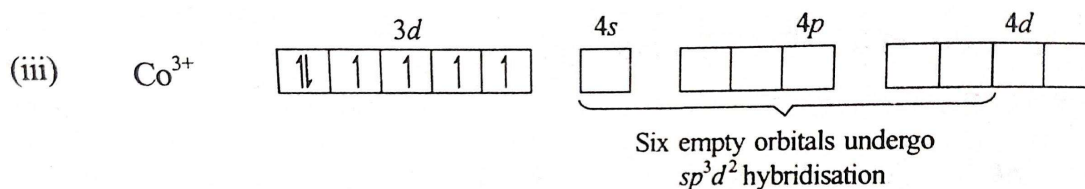

2. TETRAHEDRAL COMPLEXES

These complexes are formed by the sp^3 hybridisation.

ex:-Formation of Nickel TetraCarbonyl [Ni(CO)₄]

- ❖ In this complex the central atom is Ni.
- ❖ Here nickel is present in zero oxidation state, i.e., in the form of metallic nickel. Its formation can be represented as below:

ow :

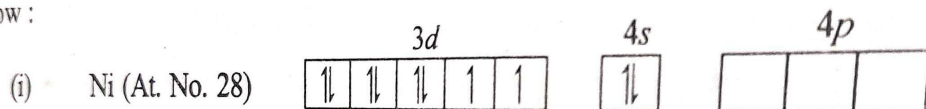

- ❖ In the presence of carbon monoxide ligand, rearrangement takes place and electrons are paired up against the Hund's rule, i.e., the two 4s electrons go to the 3d orbitals in order to vacate the 4s orbital for electrons donated by the ligand CO.
- ❖ The empty one 4s and three 4p orbitals mix (sp^3 hybridisation) to form four equivalent hybrid orbitals each of which accepts an electron pair from carbon monoxide molecule forming Ni(CO)₄

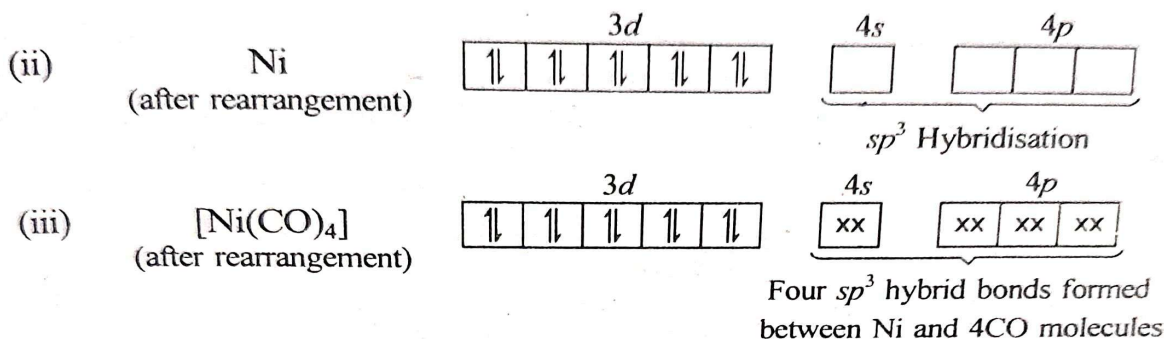

Thus, nickel tetracarbonyl is tetrahedral and diamagnetic in nature.

3. SQUARE PLANAR COMPLEXES

These are formed by dsp^2 hybridisation. These complexes tend to be formed when the central ion has only one d orbital available in the inner shell.

Ex:- Formation of [Ni(CN)₄]²⁻:

- ❖ In this complex the central atom is Nickel.
- ❖ The electronic configuration of the nickel atom and Ni²⁺ ion are depicted below:

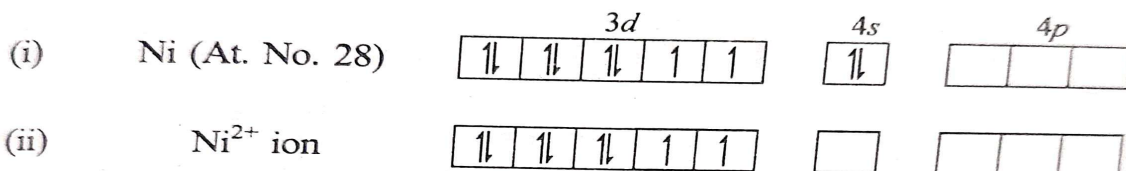

- ❖ Since, the coordination number of Ni in this complex is 4, the configuration of Ni, at first sight, shows that the complex is formed by sp^3 hybridisation and it is paramagnetic as it has two unpaired electrons.

- ❖ However, experiments show that the complex is diamagnetic, ie, it does not have any unpaired electron. This is possible when the 3d electrons rearrange against the Hund's rule as shown below. This is also in accordance with the fact that the ligand involved here is a strong, ie, CN^- ion.

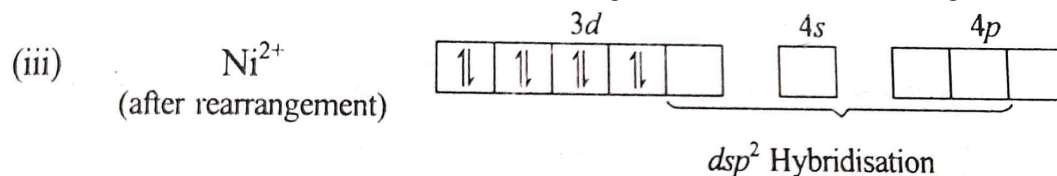

- ❖ Hence, nickel undergoes dsp^2 hybridisation, involving one 3d, one 4s and two 4p orbitals, leading to four dsp^2 hybrid orbitals, each of which accepts an electron pair from CN^- ion forming $[\text{Ni}(\text{CN})_4]^{2-}$ ion.

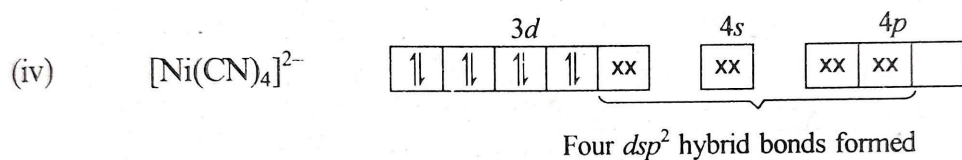

The resulting complex is square planar and is *diamagnetic* as it has no unpaired electron.

Limitations of valence bond theory (VBT):

1. Although it provides a satisfactory pictorial representation of the complex qualitatively, it does not provide quantitative interpretation of the stability of complexes.
2. It does not explain the spectra (colour) of the complexes.
3. Based on the number of unpaired electrons this theory cannot distinguish between a) d^2sp^3 and sp^3d^2 b) sp^3 & dsp^2 hybridization
4. It does not give any detailed information about the magnetic properties of complexes. In particular it cannot explain the temperature dependent paramagnetism of the complexes.
5. It does not explain why at one time the electrons must be arranged against the Hund's rule while at other times the electronic configuration is not disturbed.
6. It does not provide any satisfactory explanation for the existence of inner orbital and outer orbital complexes
7. It cannot explain why certain complexes are more labile than others. Labile complexes are those in which one ligand can be easily displaced by another ligand. On the other hand, inert complexes are those in which displacement of ligands is slow.

CRYSTAL FIELD THEORY

The crystal field theory was proposed by Hans Bethe and VanVleck. This theory gives a satisfactory explanation for the bonding and various properties like color, magnetic properties of complexes than the valence bond theory.

Assumptions of Crystal field theory:

- ❖ The interaction between the metal ion and the ligand is purely electrostatic(Ionic).
- ❖ Negative ligands are treated as point charges and neutral ligands are treated as dipoles.
- ❖ In a free metal ion, all the five d-orbitals have the same energy. These orbitals having the same energies are called **degenerate orbitals**. This means that an electron can occupy any one of these five d-orbitals with equal ease.
- ❖ On the approach of the ligands, the orbital electrons will be repelled by the lone pairs (or negative charges) of the ligands. The repulsion will raise the energy of the d-orbitals.
- ❖ If all the ligands approaching the central metal ion are at equal distance from each of the d-orbitals, the energy of each orbital will increase by the same amount, due to the spherical field or symmetrical field of ligands.
- ❖ Therefore, these orbitals will still remain degenerate, but they will have higher energy than that of the free ion. d-orbitals have different orientations and, therefore, these orbitals will experience different interactions from the ligands.
- ❖ In order to understand the crystal field splitting, it is necessary to recapitulate the shapes of the five d-orbitals.
- ❖ Of the five d-orbitals three namely d_{xy} , d_{yz} & d_{zx} orbitals have maximum electron density directed between the X, Y and Z axes. The set of these orbitals is collectively known as **t_{2g} -orbitals**. The d_z^2 orbitals have maximum electron density along the Z- axis while the $d_{x^2-y^2}$ orbitals has maximum electron density along the X-axis and Y-axis. These two orbitals are together known as **e_g -orbitals**.

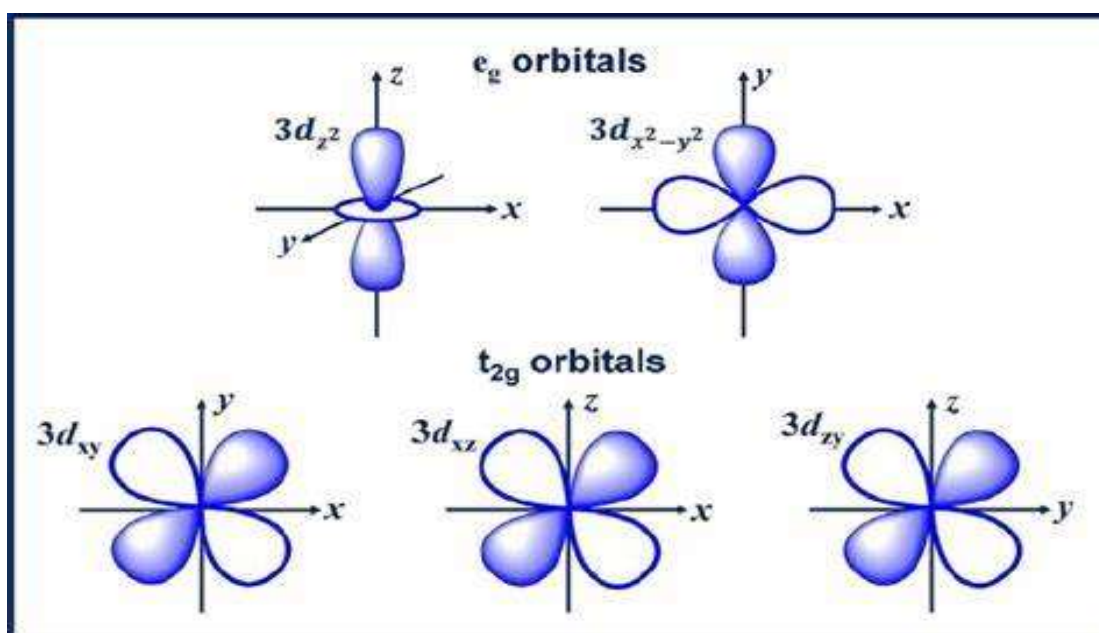

- ❖ The orbitals lying in the direction of the ligands, will experience greater repulsion and their energies will be raised relative to their positions in a symmetrical field.
- ❖ The orbitals lying away from the approach of the ligands will have lesser interactions with the negative charge of donor atoms and therefore, their energies will be lower than they would be in a spherical field, Therefore, due to the electrical field of the ligands, the energies of the five d-orbitals will split up.
- ❖ This conversion of five degenerate d-orbitals of the metal ion into different sets of orbitals having different energies in the presence of electrical field of ligands is called **crystal field splitting**.

Crystal field splitting in octahedral complexes:

In octahedral complexes, the metal ion is at the center of the octahedron, and the six ligands lie at the six corners of the octahedron along the three axes X, Y and Z.

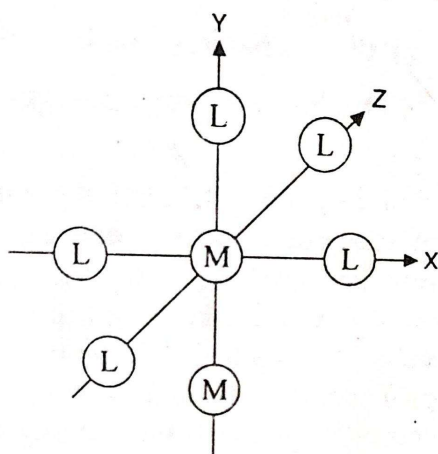
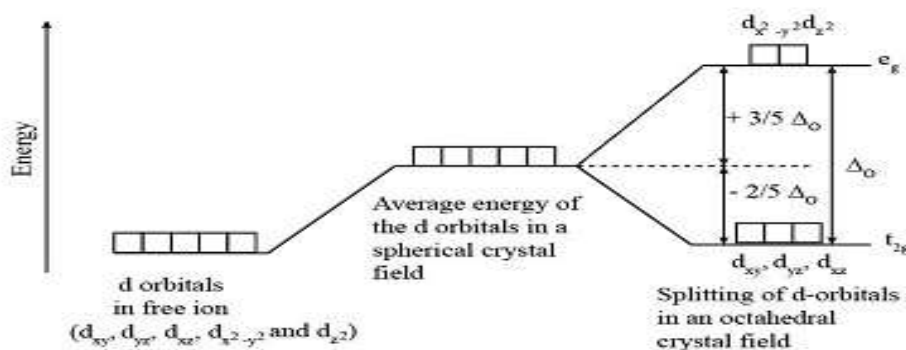

Fig. 1.2. The octahedral complex showing the placement of the six ligands along the three axes (L represents ligand)

- ❖ The d-orbitals where electron density is oriented along the axes, $d_{x^2-y^2}$ and d_{z^2} are repelled much more by the ligands while the orbitals d_{xy} , d_{xz} , d_{yz} having electron density oriented in between the axes are repelled lesser by the ligands.
- ❖ Therefore, the energies of d_{xy} , d_{xz} , d_{yz} orbitals are lower than those of $d_{x^2-y^2}$ and d_{z^2} orbitals.
- ❖ The orbitals of lower energy are called **t_{2g} -orbitals** and orbitals of higher energy are called **e_g -orbitals**.
- ❖ Under the influence of the ligands, the degeneracy of the five d orbitals of the metal ion is lost and they are split into two groups of orbitals of different energies. This effect is known as crystal field splitting.
- ❖ The difference of energy between the two sets of d- orbitals is called crystal field splitting energy or crystal field stabilization energy (CFSE). It is represented as Δ_0 where, O' stands for the octahedral complex. Some times the Δ_0 is replaced by $10 Dq$.



- ❖ From fig. It is clear that electrons will tend to occupy the lower energy **t_{2g}-orbitals** in order to achieve stability. Each electron entering the **t_{2g}** orbital stabilizes the complex ion by $0.4\Delta_0$ units and each electron entering the higher energy **e_g** orbital destabilize the complex ion by $0.6\Delta_0$ units
- ❖ The crystal field splitting (Δ_0) depends upon the nature of the ligands. The greater the ease with which the ligand can approach the metal ion, the greater will be the crystal field splitting caused by it. The ligands which cause only a small degree of crystal field splitting are called **weak field ligands** while those which cause a large splitting are called **strong field ligands**.

Spectrochemical Series

The ligands can be arranged according to the magnitude of the Δ_0 and this arrangement is called **spectrochemical series**. The spectrochemical series in the increasing order of crystal field splitting is given below :

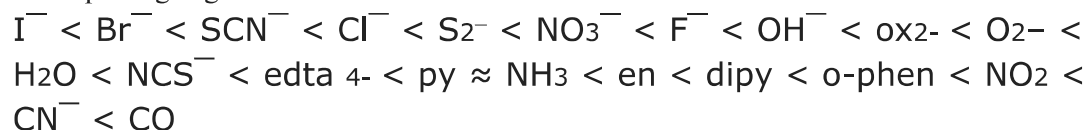

- ❖ The ligands lying above H₂O are called strong field ligands and they cause greater crystal field splitting (or high Δ°). Ex- NO₂ ,CN⁻ ,CO
- ❖ The ligands below to water are called **weak field ligands** and they cause lesser crystal field splitting (or low Δ°). Ex- I⁻ , Br⁻ ,SCN⁻ ,Cl⁻

Crystal field splitting Tetrahedral complexes

- ❖ In a tetrahedral complex, the metal ion is at the center of the regular tetrahedron and ligands are at the four alternate corners of the tetrahedron.

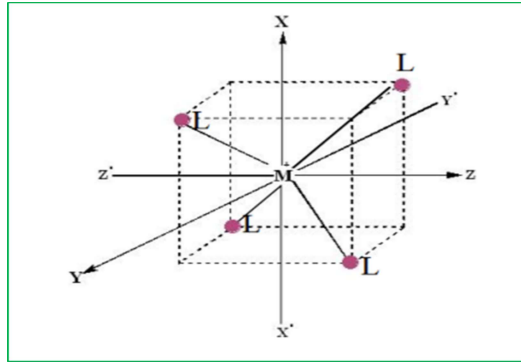

- ❖ From the figure it is obvious that the ligands interact more with the t_{2g} -orbitals (d_{xy} , d_{xz} , d_{yz} orbitals) pointing close to the direction of the approaching ligands than the e_g -orbitals ($d_{x^2-y^2}$ and d_{z^2} orbitals) lying between the ligands.
- ❖ In free metal ion, all the five d-orbitals have the same energy i.e. they are degenerate (State-I). As the ligands approach the central metal ion, repulsion will take place between metal electrons and the negative electric field of ligands. This repulsion will raise the energy levels of d-orbitals. If all the ligands approaching metal ion are at an equal distance from each of the d-orbitals, then the energy of each d-orbital will increase by the same amount i.e. they will remain degenerate (State-II). However, this is only a hypothetical situation.
- ❖ Because of different directional properties, the five d-orbitals will be repelled to different extents. Therefore their energies no longer remain the same but split up into two sets of orbitals called e and t_2 . The e orbitals include $d_{x^2-y^2}$ and d_{z^2} orbitals while “ t ” orbitals include d_{xy} , d_{yz} , and d_{xz} orbitals.

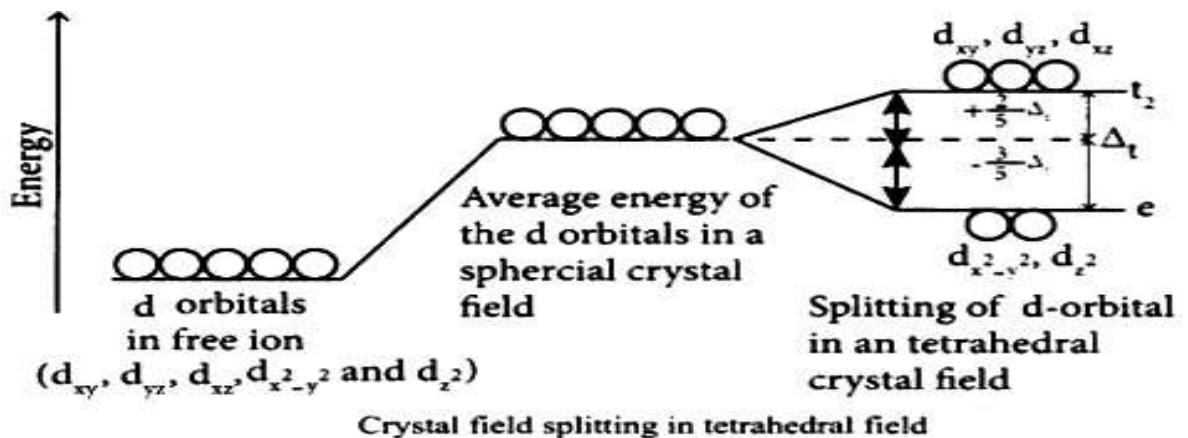

- ❖ 'e' orbitals, which lie along the axes, do not face the ligands directly and hence will experience less repulsion. Therefore it will be lowered in energy by $-6Dq$ relative to barycenter. On the other hand, 't₂' orbitals which lie in between the axes, also do not face the ligands directly but are closer to ligands than 'e' orbitals and hence will experience more repulsions. Therefore it will be raised to a higher energy level by $+4Dq$ relative to the barycenter.
- ❖ The difference in energy between the two sets of d-orbitals is denoted by $10 Dq$ or Δ_t and is called crystal field splitting energy in tetrahedral complexes
- ❖ It is found that the Δ_t value is always less than that of Δ_o

$$i. e. \Delta_t = \frac{4}{9} \Delta_o$$

Crystal field splitting in Square Planar complexes

- ❖ The square planar arrangement of ligands may be considered to be one derived from the octahedral field by removing two trans-ligands located along the Z-axis.
- ❖ In the process, the **eg** and **t_{2g}** sets of orbitals is lifted i.e., these orbitals will no longer be degenerate.

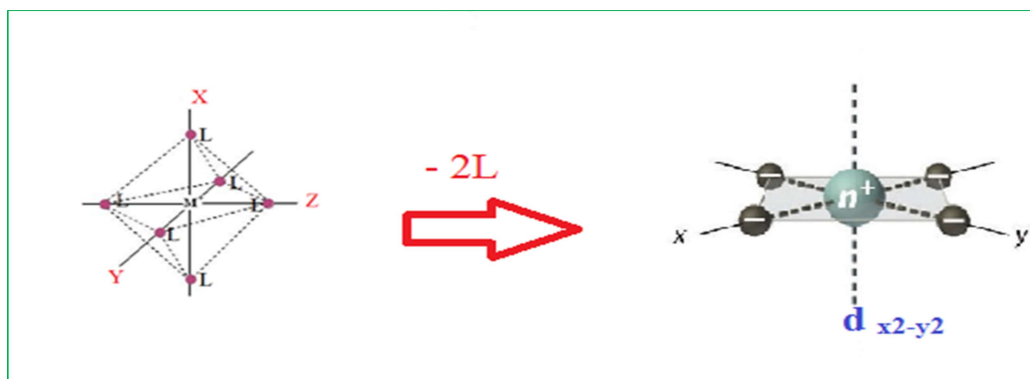

- ❖ This changes the distribution of the *d* orbitals, as orbitals on or near the *z*-axis become more stable, and those on or near the *x*- or *y*-axes become less stable.
- ❖ This results in the octahedral **t_{2g}** and the **e_g** sets splitting and gives a more complicated splitting pattern as shown in the figure.

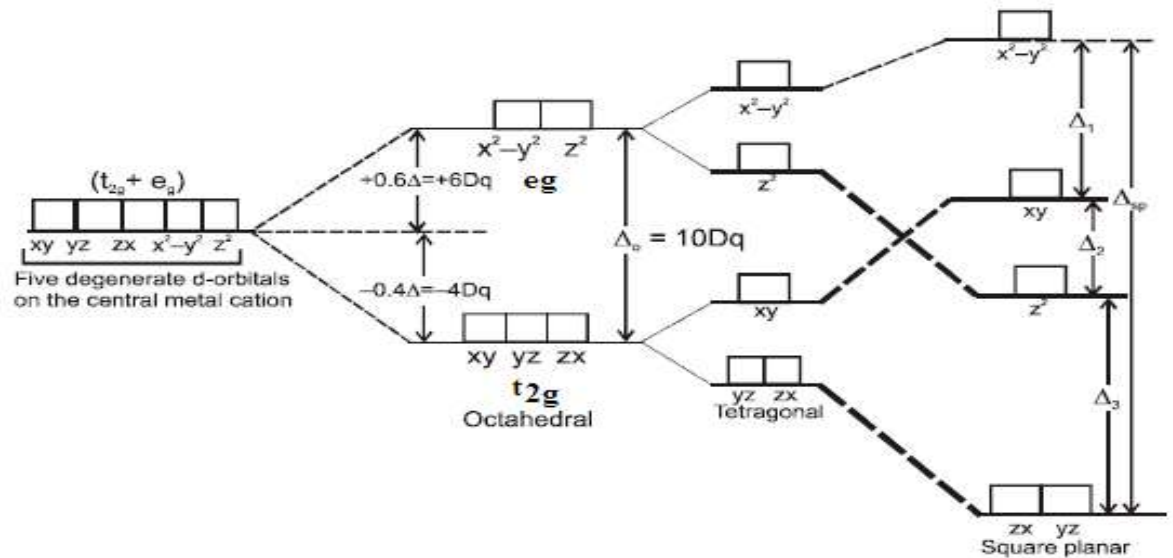

- ❖ The value of Δ_{sp} has been found larger than Δ_o because of the reason that d_{xz} and d_{yz} orbitals interact with only two ligands in the square planar complexes, while in octahedral complexes the interaction takes place only with four ligands. Δ_{sp} has been found equal to $1.3 \Delta_o$.

$$\Delta_1 > \Delta_2 > \Delta_3 ; \text{ sometimes it can be } \Delta_1 > \Delta_3 > \Delta_2$$

$$\text{But, } \Delta_{sp} = (\Delta_1 + \Delta_2 + \Delta_3) > \Delta_o$$

$$\text{and } \Delta_{sp} = 1.3 \Delta_o$$

Factors effecting the crystal field splitting

1. Nature of the ligand: The crystal field splitting (Δ_o) depends upon the nature of the ligands. The greater the ease with which the ligand can approach the metal ion, the greater will be the crystal field splitting caused by it. The ligands which cause only a small degree of crystal field splitting are called **weak field ligands** while those which cause a large splitting are called **strong field ligands**.

The ligands can be arranged according to the magnitude of the Δ_o and this arrangement is called **spectrochemical series**. The spectrochemical series in the increasing order of crystal field splitting is given below :

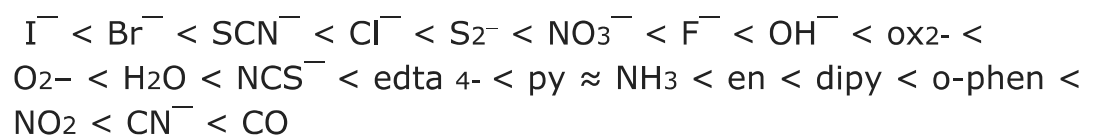

1. **Oxidation state of the metal ion:** The metal ion with higher oxidation state causes larger crystal field splitting than is done by the ion with lower oxidation state.
2. **Types of d- orbitals:** The extent of c.f.s for similar complexes of metal in the same oxidation state increased by about thirty to fifty percent on going from first transition series to third transition series. The increase is almost same amount as going from the second transition series to the third transition series. This may be explained on the basis that 4d orbital in comparison to 3d orbital are bigger in size.as a result 4d orbital interacts strongly with ligand.
3. **Geometry of the complex :** Crystal field splitting energy of tetrahedral complexes is nearly half the value for octahedral complexes.

$$i.e. \Delta_t = \frac{4}{9} \Delta_0$$

In other words, the value of c.f.s.e for tetrahedral complexes is small as compared to pairing energy p. The tetrahedral complexes are therefore mostly high spin complexes.

Crystal Field Stabilization Energy(CFSE)

A consequence of Crystal Field Theory is that the distribution of electrons in the orbitals can lead to stabilization for some electron configurations. In octahedral complexes it is clear that electrons will tend to occupy the lower energy **t_{2g}-orbitals** in order to achieve stability. Each electron entering the **t_{2g}** orbital stabilizes the complex ion by $0.4\Delta_0$ units and each electron entering the higher energy **e_g** orbital destabilize the complex ion by $0.6\Delta_0$ units, i.e., the stabilization energy in the two cases is $0.4\Delta_0$ and $-0.6\Delta_0$ respectively.

- ❖ The gain in energy achieved by preferential filling up of orbitals by electrons is known as **Crystal Field Stabilization Energy(CFSE)**.
- ❖ Greater the amount of CFSE of the complex, greater is the stability of the complex.

Table 1.6. Filling up of d -orbitals in the octahedral complexes in presence of strong ligand field

No. of d -electrons in the metal ion	Distribution of electrons					Stabilisation energy	No. of unpaired electrons
	t_{2g} orbitals			e_g orbitals			
1.	↑					$0.4 \Delta_0$	1
2.	↑	↑				$0.8 \Delta_0$	2
3.	↑	↑	↑			$1.2 \Delta_0$	3
4.	↑↓	↑	↑			$1.6 \Delta_0$	2
5.	↑↓	↑↓	↑↓			$2.0 \Delta_0$	1
6.	↑↓	↑↓	↑↓			$2.4 \Delta_0$	0
7.	↑↓	↑↓	↑↓	↑		$1.8 \Delta_0$	1
8.	↑↓	↑↓	↑↓	↑	↑	$1.2 \Delta_0$	2
9.	↑↓	↑↓	↑↓	↑↓	↑↓	$0.6 \Delta_0$	1
10.	↑↓	↑↓	↑↓	↑↓	↑↓	$0.0 \Delta_0$	0

Table 1.7. Filling up of d -orbitals in the octahedral complexes in presence of weak ligand field

No. of d -electrons in the metal ion	Distribution of electrons					Stabilisation energy	No. of unpaired electrons
	t_{2g} orbitals			e_g orbitals			
1.	↑					$0.4 \Delta_0$	1
2.	↑	↑				$0.8 \Delta_0$	2
3.	↑	↑	↑			$1.2 \Delta_0$	3
4.	↑	↑	↑	↑		$0.6 \Delta_0$	4
5.	↑	↑	↑	↑	↑	$0.0 \Delta_0$	5
6.	↑↓	↑	↑	↑	↑	$0.4 \Delta_0$	4
7.	↑↓	↑↓	↑	↑	↑	$0.8 \Delta_0$	3
8.	↑↓	↑↓	↑↓	↑	↑	$1.2 \Delta_0$	2
9.	↑↓	↑↓	↑↓	↑↓	↑	$0.6 \Delta_0$	1
10.	↑↓	↑↓	↑↓	↑↓	↑↓	$0.0 \Delta_0$	0

ISOMERISM IN COMPLEX COMPOUNDS

The complex Compounds having the same molecular formula but they have different molecular/group arrangements and show different properties are called isomers. This phenomenon is called isomerism. Differences in one or more physical or chemical properties due to the presence of different spatial molecular/group arrangements.

Coordination compounds show two types of isomerism, i.e., structural isomerism and stereoisomerism.

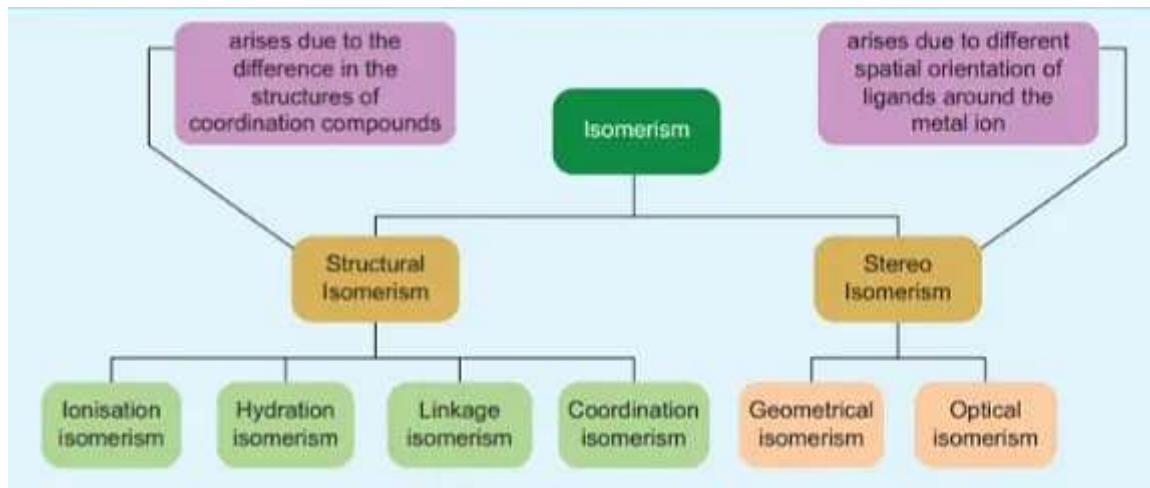

I. Structural isomerism:

The isomerism which arises due to the difference in the structure of complexes is called structural isomerism. It is due to the different ionisation behaviour, the difference in the position of ligand and the different modes of linkage of ligands. The different types of structural isomerism are:

1. Ionisation isomerism
2. Hydrate or solvate isomerism
3. Linkage isomerism
4. Coordinate isomerism
5. Ligand isomerism

1. Ionisation Isomerism

The coordinate compound having the same molecular formula but showing a different ionisation behaviour and furnishing different ions in the solution is called ionisation isomers. The phenomenon is called ionisation isomerism.

Ex- $[\text{Co}(\text{NH}_3)_5\text{Br}]\text{SO}_4$ and $[\text{Co}(\text{NH}_3)_5(\text{SO}_4)]\text{Br}$ ionise as follows:

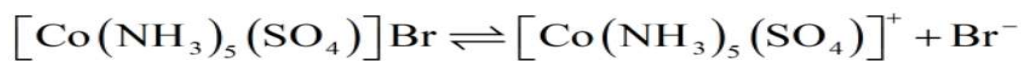
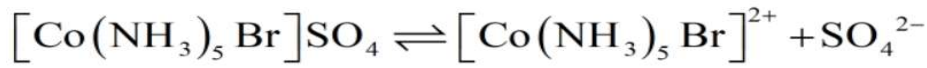

The complex $[\text{Co}(\text{NH}_3)_5\text{Br}]\text{SO}_4$ is red-violet, and its aqueous solution gives a white precipitate of BaSO_4 with BaCl_2 . Whereas, $[\text{Co}(\text{NH}_3)_5(\text{SO}_4)]\text{Br}$ is red, and its aqueous solution gives a light yellow precipitate of AgBr with AgNO_3 .

2. Hydrate or Solvate Isomerism

Compounds with the same composition but differ in the number of solvent molecules present in the ligand and as a free solvent molecule in a crystal lattice are called solvate isomers. The phenomenon is called hydrate isomerism if water is the solvent, these are called hydrate isomers.

(or)

The isomers differing in the number of water molecules attached to the metal ion as ligands in the coordination sphere are called hydrate isomers and this phenomenon is classed hydrate isomerism.

$[\text{Cr}(\text{H}_2\text{O})_6]\text{Cl}_3$ having three ionic chlorides is violet in colour.

$[\text{Cr}(\text{H}_2\text{O})_5\text{Cl}]\text{Cl}_2 \cdot \text{H}_2\text{O}$ having two ionic chlorides is blue-green.

3. Linkage Isomerism

Linkage isomerism is observed in the compounds containing ambidentate ligands, i.e., when more than one atom in a unidentate ligand may function as a donor.

Ex- The pentaamminenitrocobalt (III) ion, i.e., $[\text{Co}(\text{NO}_2)(\text{NH}_3)_5]^{2+}$ and pentaamminenitritocobalt (III) ion, i.e., $[\text{Co}(\text{ONO})(\text{NH}_3)_5]^{2+}$. In NO_2^- either nitrogen or an oxygen atom may act as a donor giving to different isomers.

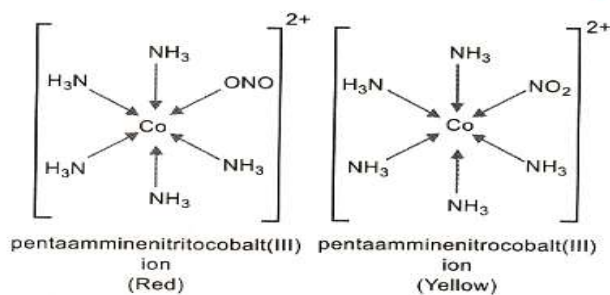

4. Coordination Isomerism

The isomerism due to the interchange of ligands between the positive and negative part of the coordination sphere is called coordination isomerism. Coordination isomerism is shown by the complexes in which both positive and negative parts are complex species.

Ex- $[\text{Co}(\text{NH}_3)_6][\text{Cr}(\text{C}_2\text{O}_4)_3]$ and $[\text{Co}(\text{C}_2\text{O}_4)_3][\text{Cr}(\text{NH}_3)_6]$

II. STEREO ISOMERISM:

Stereo isomerism is the type of isomerism in which two substances of the same composition and even same constitution differ only in the relative position in space assumed by certain of their constituent atoms or groups or ligands.

Stereo isomerism is of two types.

1. Geometrical isomerism
2. Optical isomerism

1. Geometrical Isomerism:

Because of the various geometric arrangements of the ligands, this type of isomerism occurs in heteroleptic complexes. In this isomerism the ligands occupy different positions around the central metal ion.

When the two identical ligands are adjacent to each other, the isomer is known as **cis isomer**. While when the two identical ligands are opposite to each other the isomer is known as **trans isomer**.

Geometrical isomers differ in physical as well as chemical properties.

Geometrical isomerism in complexes with coordination 4:

The complexes with C.N 4 may lacquer either of the two geometries.

1. Tetrahedral
2. Square planar complexes

Tetrahedral complexes do not exhibit cis-trans isomerism because all the four ligands are equidistant from one another.

Geometrical isomerism in square planar complexes

The geometrical isomerism is very common amongst square planar complexes. However it is important to note that complexes of the type $\text{Ma}_4, \text{Ma}_3\text{b}, \text{Mab}_3$ do not exhibit geometrical isomerism. But the square planar complexes of the type $\text{Ma}_2\text{b}_2, \text{Ma}_2\text{bc}, \text{Mabcd}$ may exist in cis- trans forms.

Where a,b are different monodentate ligands.

1. $[\text{Ma}_2\text{b}_2]$ - type:

Example : $[\text{Pt}(\text{NH}_3)_2\text{Cl}_2]$

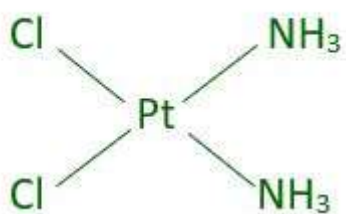

cis

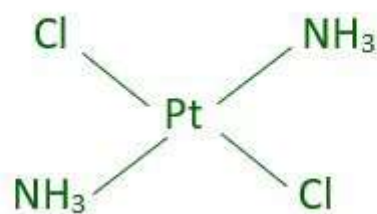

trans

Geometrical isomers (cis and trans) of $\text{Pt}[(\text{NH}_3)_2\text{Cl}_2]$

2. **[Ma₂bcl]-type :**

Example: $[\text{Pt}(\text{NH}_3)_2(\text{Cl})\text{NO}_2]$

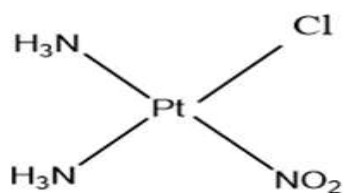

Cis - isomer

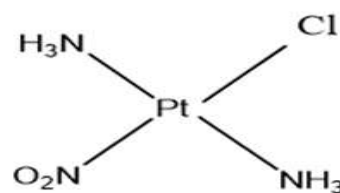

Trans - isomer

3. **[Mabcd]-Type:** This type of complexes exhibit three type of geometrical isomers.

Example: $[\text{Pt}(\text{NH}_3)(\text{Py})(\text{Cl})(\text{Br})]$

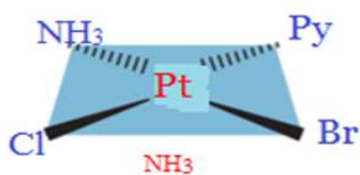

Trans to Br

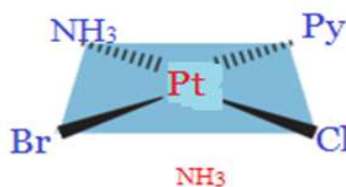

Trans to Cl

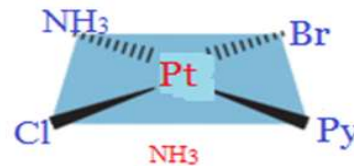

Trans to Py

Geometrical isomerism in complexes with coordination 6:

The complexes with Coordination Number 6 have Octahedral geometry.

Geometrical isomerism in Octahedral complexes

Geometrical isomerism is the most common thing in sixth coordination compounds. General formulas of these compounds exhibiting Geometrical isomerism are:

- i). $[Ma_4b_2]$
- ii). $[M(a-a)_2b_2]$
- iii). $[Ma_3b_3]$

1. $[Ma_4b_2]$ Type:

Example: $[Co(NH_3)_4Cl_2]^+$

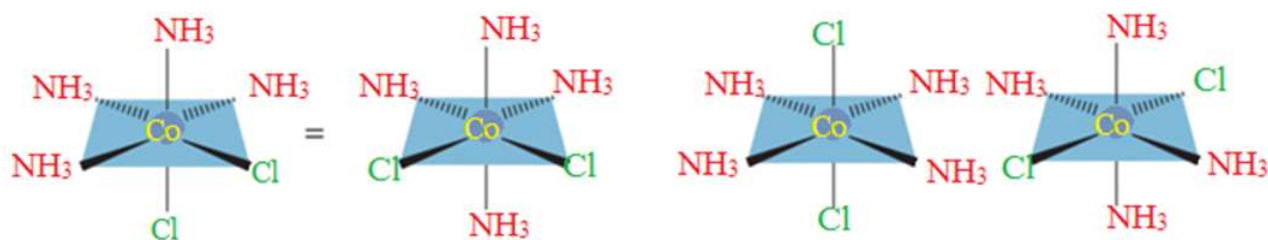

Cis - Isomer

Trans - Isomer

2. $[M(a-a)_2b_2]$ type:

Example: $[Co(en)_2Cl_2]^+$

en = $NH_2-CH_2-CH_2-NH_2$

Ethylenediamine a bidentate ligand

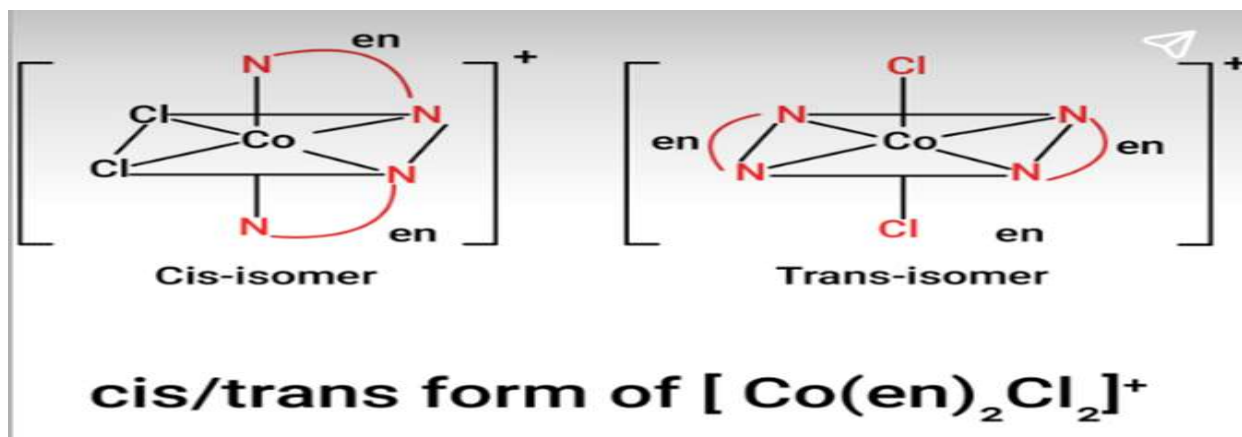

3. $[Ma_3b_3]$ - type:

This type of complexes show cis or facial (fac) and trans or meridional (mer) isomerism.

In cis isomer the three a ligands lie on the corners of the triangular face of the octahedron and the three b ligands lie on the corners of the opposite triangular face of the octahedron.

In trans form the three a ligands lie around one edge of the octahedron and the three b ligands lie around the opposite edge of the octahedron.

Ex: $[Rh(Py)_3Cl_3]$

Py = pyridine

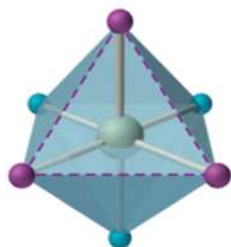

MA_3B_3 octahedral complex, *fac* isomer

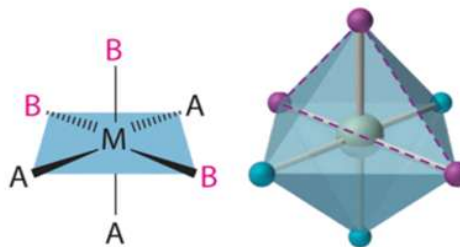
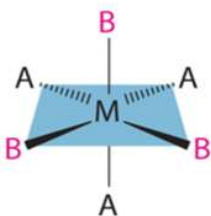

MA_3B_3 octahedral complex, *mer* isomer

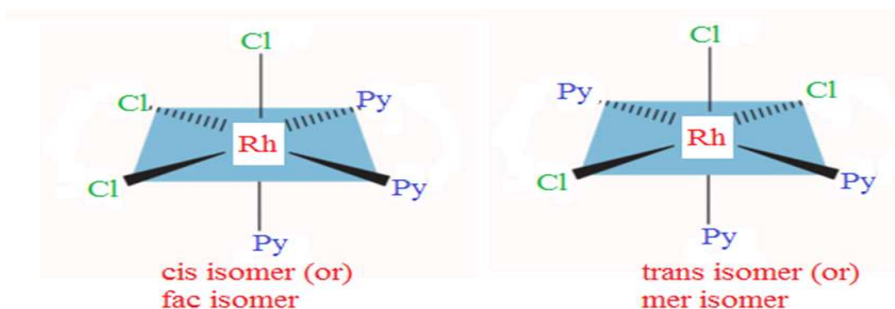

cis isomer (or)
fac isomer

trans isomer (or)
mer isomer

2. Optical Isomerism:

When the same molecular formula represents two compounds which have similar chemical and physical properties but differ in their action towards plane polarized light, then these are known as optical isomers, this phenomenon is called optical isomerism.

Similar pairs of some coordinate compounds are mirror images of each other. That is, one cannot superimpose the other. Such isomers are called polar isomers or optical isomers.

If a compound has no plane of symmetry, it exhibits optical activity. Such combinations can be termed as optical isomers.

The isomers which rotate the plane polarized light towards the right hand side are called **dextro-rotatory** compounds or d-compounds.

While the isomers which rotate the plane polarized light towards the left hand side are called **leavo-rotatory** compounds or l-compounds.

i).Optical isomerism in complexes with coordination 4:

Among four coordinate complexes, optical isomerism is not possible in square planar complexes since they contain horizontal plane of symmetry.

Hence among such complexes optical isomerism is encountered only in tetrahedral complexes.

Tetrahedral complexes containing two unsymmetrical bidentate ligands have been resolved into optically active isomers.

The most common example is bis (benzoylacetaonato) beryllium(II)

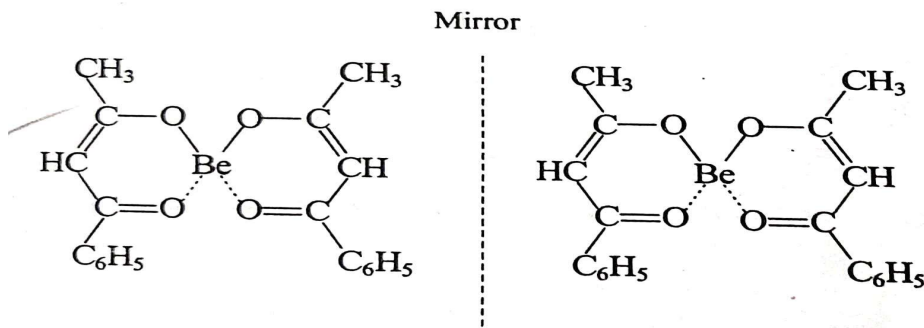

ii). Optical isomerism in complexes with coordination 6:

Octahedral complexes(complexes with CN-6) constitute the most well known examples of optical isomerism.

The octahedral complexes of the following type can be resolved into optically active isomers.

1. $[M(a-a)b_2c_2]$,
2. $[M(a-a)_2b_2]$
3. $[M(a-a)_3]$ or $[M(a-b)_3]$

Where

M = central atom

(aa) = symmetrical bidentate ligands

(ab) = unsymmetrical bidentate ligands

b, c = Monodentate ligands

1. $[M(a-a)b_2c_2]$ - type:

Ex: $[Co(en)(NH_3)_2Cl_2]^+$

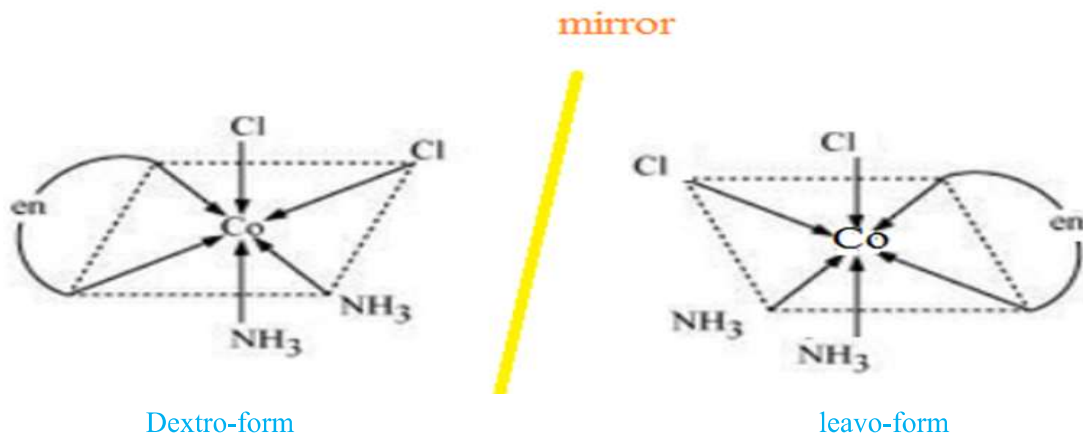

2. $[M(a-a)_2b_2]$ - type:

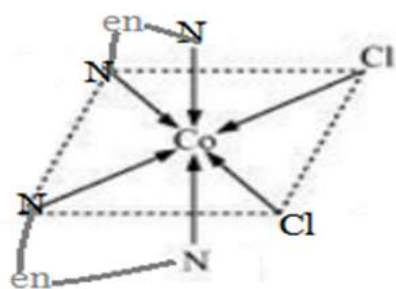
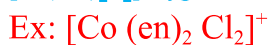

Dextro - form

mirror

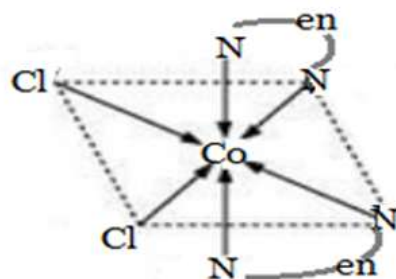

leavo - form

3. $[M(a-a)_3]$ type:

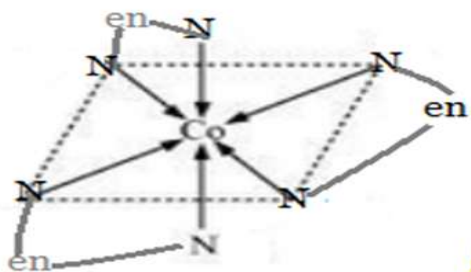

mirror

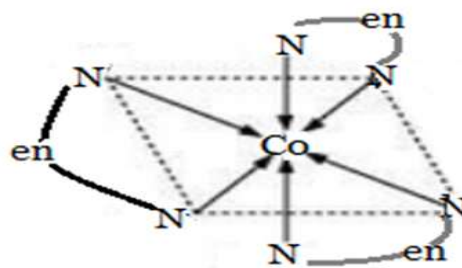

4. Complexes containing hexadentate ligand: complexes containing hexadentate ligand have also been resolved into d- and l- forms.

The typical example is $[Co(EDTA)]^-$, where EDTA is ethylene diamine tetra acetate

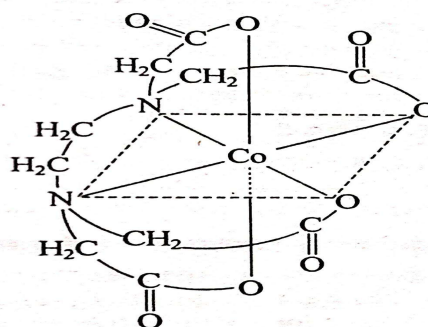
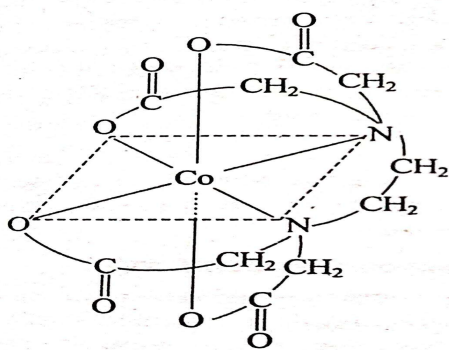

Enantiomeric pair of $[Co(EDTA)]^-$